

Coca-Cola freestyle. Flex | User Guide



This guide provides general tips and proper maintenance procedures for your Coca-Cola Freestyle® Flex dispenser.

Contents

EQUIPMENT

- External components 4
- Internal and backroom components 5

OPERATIONS

- Ways to pour a drink 6
- Pouring with ADA interface 7
- Mobile pour 8
- Filling the ice bin 9
- Accessing the ingredient summary and crew dashboard 10
- Understanding the ingredient summary 11
- Understanding the crew dashboard 12
- Cartridge prime procedure 13
- Manager lock mode 14
- Calorie counter display 15
- Using & pairing with myCoke mobile app 16

PRODUCT REPLACEMENT

- Replacing cartridges and NNS 18
- Replacing HFCS sweetener 20

MAINTENANCE

- Helpful cleaning tips 21
- Cleaning nozzle, injector ring, and ice chute 22
- Cleaning ice bin 23
- Cleaning drain and cup rest 24
- Cleaning exterior surfaces 25
- Cartridge maintenance 26

RESOURCES

- Small parts 27
- Crew Connect 28



For crew training videos, visit crewconnect.coca-cola.com



External components

- A** Ice bin lid
- B** Cartridge access door
- C** Touch screen
- D** Nozzle and injector ring
- E** Ice chute
- F** ADA interface
- G** Cup rest and drain pan with drain strainer
- H** Key

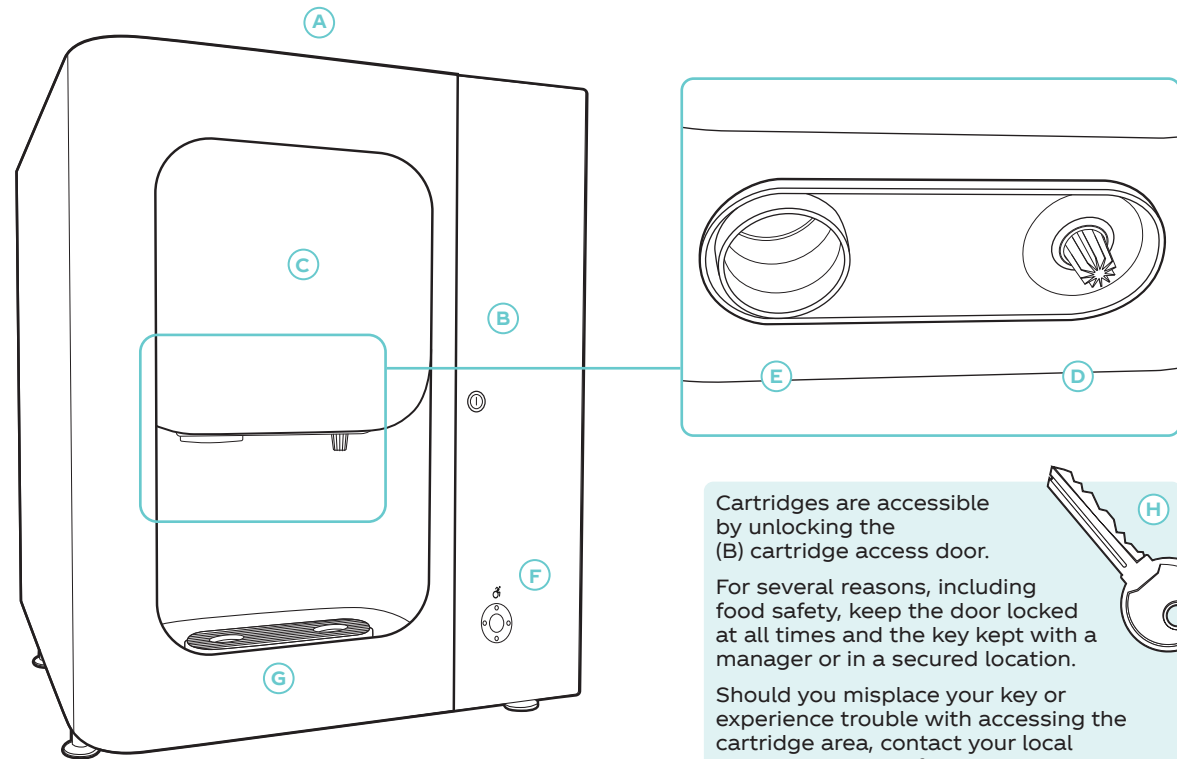

Cartridges are accessible by unlocking the (B) cartridge access door.

For several reasons, including food safety, keep the door locked at all times and the key kept with a manager or in a secured location.

Should you misplace your key or experience trouble with accessing the cartridge area, contact your local service technician for support.

Internal and backroom components

- A** Product cartridge
- B** Brand identification strip
- C** Power switch*

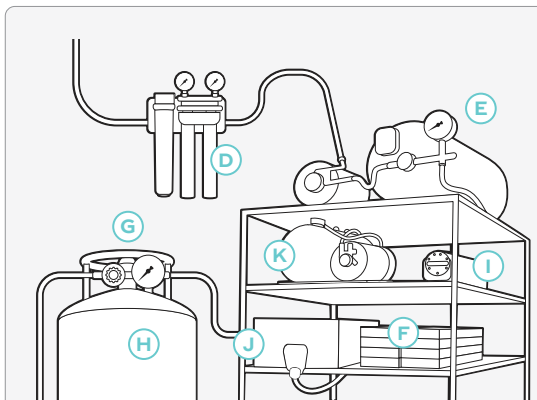
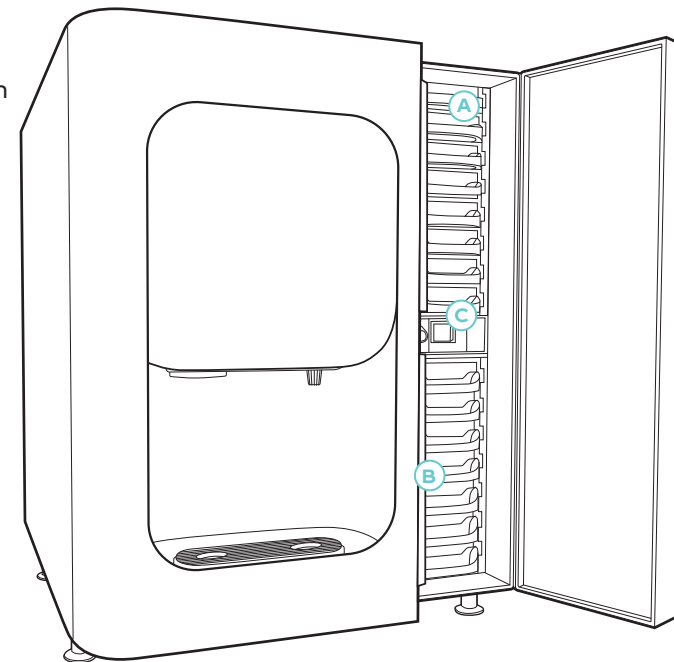

Backroom components

- D** Water filtration system
- E** Water booster
- F** Cartridge storage
- G** CO₂ gauge
- H** CO₂ tank
- I** BIB pump
- J** HFCS sweetener**
- K** Carbonator

* Do not power off unless requested by a Coca-Cola Senior Technician or as instructed for safety when cleaning.

** HFCS sweetener may be installed under-the-counter instead of the backroom.

Ways to pour a drink

Limitless options with three ways to pour.

User interface key

A Primary Brands

When a primary brand is selected.

B Empty or Unavailable Brands

Grayed-out brand buttons indicate the brand is out and unavailable.

C Brand Flavors

Flavors available for the selected primary brand. The selected flavor is indicated by expanded size.

D Calorie Counter Display

Shows the drink calorie amount based on size.

① **Add ice**
Hold your cup under the ice chute and press **Ice Button** to dispense.

② **Select primary brand**
Choose primary beverage brand by pressing the desired **Brand Button**.

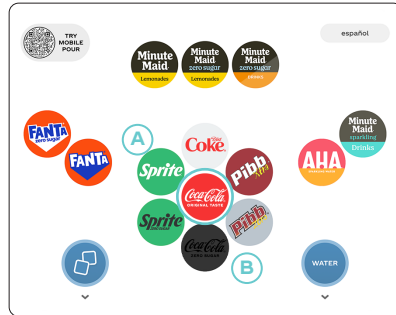

③ **Select brand flavor**
Select brand flavor by pressing **Flavor Button**. Then use the pour button to dispense your beverage.

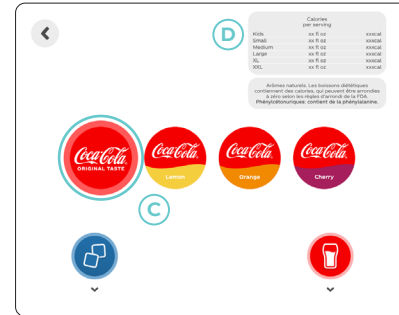

Pouring with ADA interface

Using the ADA interface

The ADA interface allows people with reach challenges (such as those in wheelchairs) to use the Coca-Cola Freestyle® dispenser without having to reach the touch screen.

- ① Press the accessibility wheelchair button to activate the ADA interface.
- ② Use the arrows to navigate to your favorite beverage.
- ③ Press the center button to pour or dispense ice.

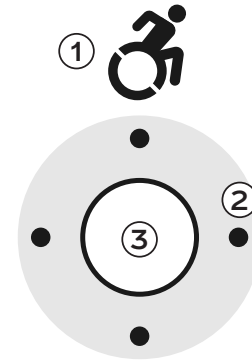

Assisting guests with pouring drinks

If someone looks like they might need assistance (e.g., he/she is visually impaired or height/reach challenged), tell your guest that you have the Coca-Cola Freestyle dispenser and that you would be happy to assist with their beverage choice.

It is up to you to determine whether the above satisfies your legal and operational obligations.



★ The ADA screen will revert back to the standard home screen after one minute of inactivity, or by pressing the wheelchair button.

Mobile Pour

How to use Mobile Pour

Mobile Pour allows customers to use their mobile phones to dispense their favorite Coca-Cola Freestyle beverages without downloading a special app or membership.

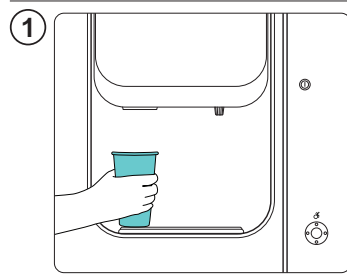

1 Hold your cup in dispenser and push on-screen button for ice.

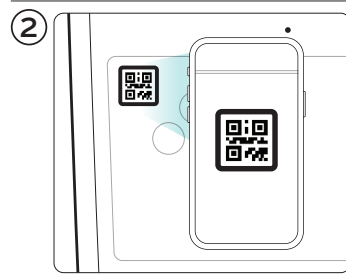

2 Scan QR code using smartphone camera. Be sure to hold your phone in front of the QR code.

NOTE: Do not hold it lower than the dispenser screen.

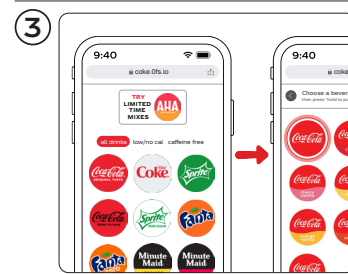

3 Select desired brand and brand flavor.

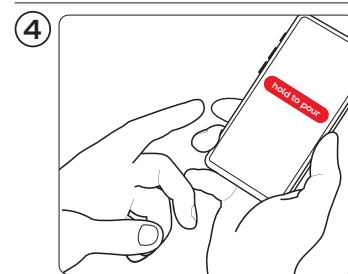

4 Press "hold to pour" button and release it to stop. Keep button pressed until cup is full.

Filling the ice bin

How to check and fill the ice bin

Maintaining the proper ice level is critical to ensuring guests receive a quality beverage.

Check to ensure ice is at least 1/3 full at all times. Fill the ice bin by following these steps. For a top-mount ice maker, follow established procedures for checking ice level.

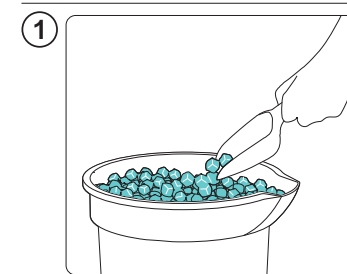

1 Fill a clean bucket with ice and open ice bin lid.

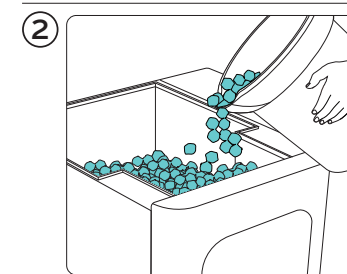

2 Dump the ice in the ice bin and fill until full (approximately 4" from the top). Do NOT overfill.

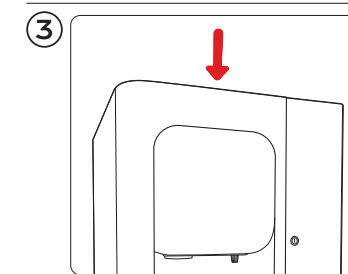

3 Close ice bin lid.

! Store-bought or "bagged ice" should NEVER be used as it may seriously damage the Coca-Cola Freestyle® Flex dispenser ice bin.

Accessing the Ingredient Summary and Crew Dashboard

1 Access Ingredient Summary

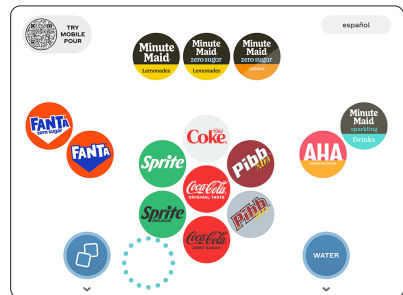

Pour Screen & secret handshake

On the all brands consumer screen, press your index finger to the lower left side of the screen to the right of the ice icon. Hold for approximately 5-6 seconds to launch the Ingredient Summary screen.

The Ingredient Summary screen can also be accessed by opening the cartridge access door.

2 Access Crew Dashboard

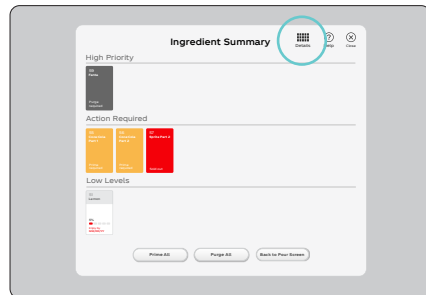

Ingredient Summary

From the Ingredient Summary screen - press the **Details Button** (grid icon) to open the Crew Dashboard.

3 Return to Pour Screen

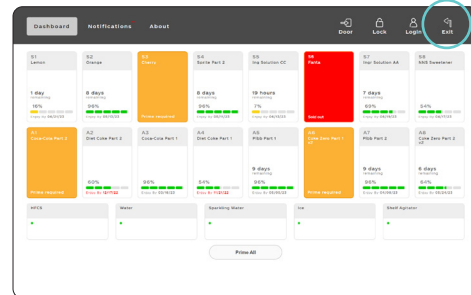

Crew Dashboard

Return to the pour screen, press the **Exit Button** (arrow icon) at the top right, and continue to follow the on-screen instructions.



If the Ingredient Summary screen or Crew Dashboard has not been accessed within the past 24 hours, a cleaning instructions screen will appear.

Understanding the Ingredient Summary

A High Priority

Items requiring immediate attention to resume function. If assistance is needed, contact your local service technician.

B Action Required

Items requiring action:

- Change the cartridge if the ingredient is shown in a red sold out status.
- Select the **Prime All Button** to prime the lines for the orange prime required gauges.

C Low Levels

Highlights ingredients (less than 20%) that are running low and will need to be replaced soon.

D Details

Use to access the Crew Dashboard.

E Back to Pour Screen (Close)

To return to the Pour Screen, select **Close** (X icon) or the **Back to Pour Screen Button**.

Remember, the cartridge access door must be closed to get back to pour screen.

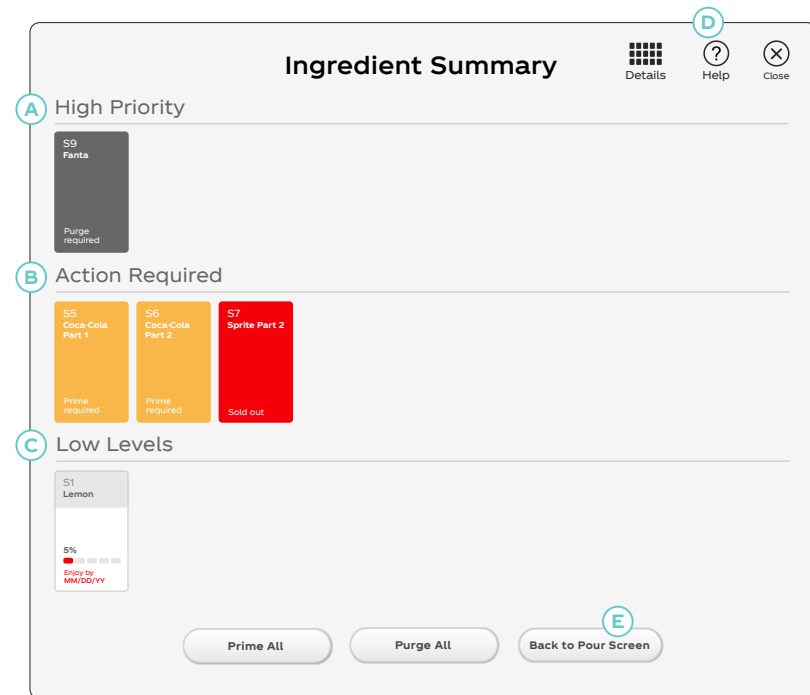

Understanding the Crew Dashboard

When crew members require a complete view of the status of all ingredients, the crew dashboard screen can be accessed.

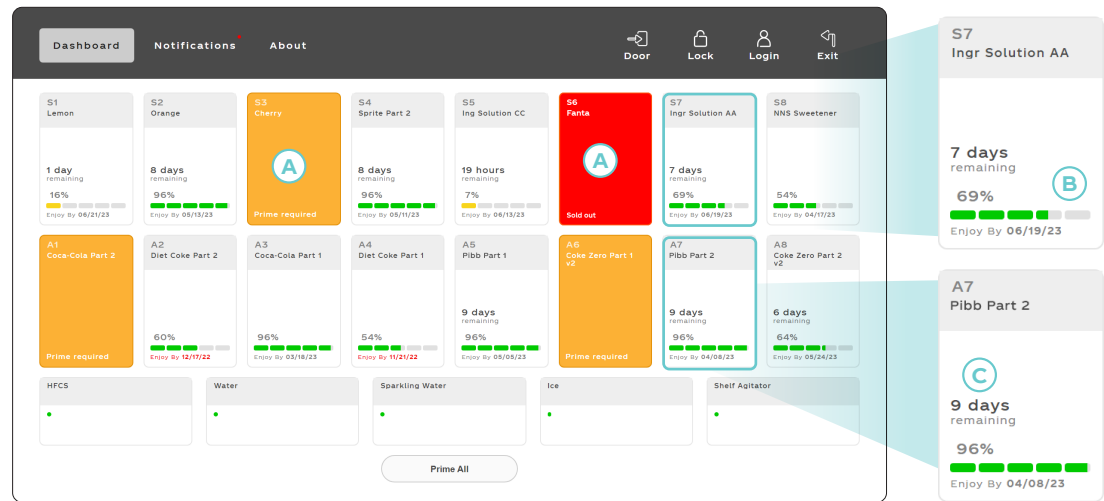

A Bold Alerts

Review items requiring attention to resume ingredient function, such as sold out, prime, or purge.

If assistance is needed, contact your local service technician.

B Fuel Gauges

Color-coded gauges displaying the remaining product percentage and Enjoy By Date of each cartridge improve cartridge change-out management for crew members and reduce product waste.

The percentage remaining and time before changing the product cartridge may vary significantly. For example, a flavor cartridge with 6% may have several days remaining, while a heavily used product cartridge, like Coca-Cola, may last only a few hours with 6%.

C Time Remaining

A time remaining feature provides an accurate reading for when each cartridge will likely run out. This new feature is calculated using the dispenser's consumption activity and daypart data to deliver a dynamic and precise reading throughout the day.

Cartridge prime procedure

Priming a product cartridge simply removes any trapped air in the line and ensures guests receive a consistent, quality beverage.

- 1 Confirm the cartridge has been inserted into the correct slot and press the **Prime All Button** at the bottom of the screen.
- 2 Priming tab will appear at the bottom of the screen during the process. It will show progress in green. When priming is complete, the tab will disappear.

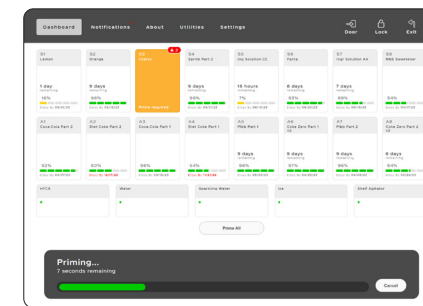
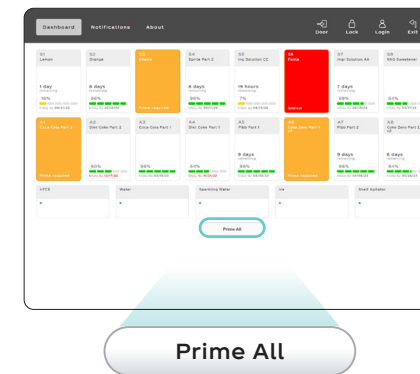

NOTE: Only press the **Prime All Button ONCE!** Pressing it more than once will needlessly repeat the prime process.

REMINDER: The prime process lasts approximately 5-10 seconds. **The process should NEVER be interrupted.**

Manager lock mode

Manager lock mode

Managers can lock the Coca-Cola Freestyle dispenser to prevent drinks from being poured without having to manually power off the unit.

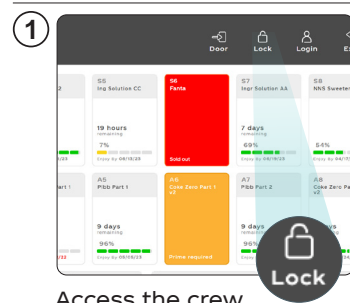

Access the crew dashboard. Then tap the **Lock** button in the top right corner.

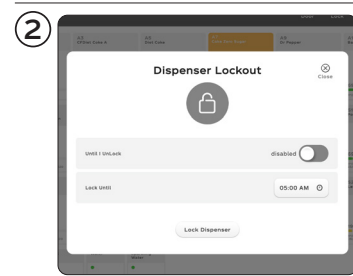

There are two ways the dispenser can be locked:

- Manual setting: Slide the 'Until I Unlock' toggle switch to enable the manual unlock feature. Once enabled, the manager must enter the passcode to unlock.
- Time setting: Tap the button next to 'Lock Until' and set a time for the dispenser to unlock automatically when 'Until I Unlock' is disabled.

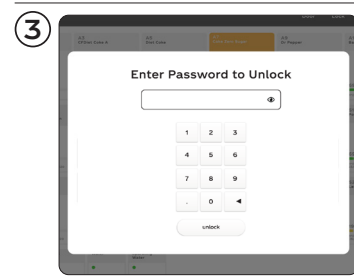

Once the dispenser is locked, you may unlock the user interface by using the manager passcode (2653).

Calorie counter display

How to enable the calorie counter display feature

To comply with the FDA menu-labeling regulations for chain establishments with 20 or more outlets, calorie counter must be accessible.

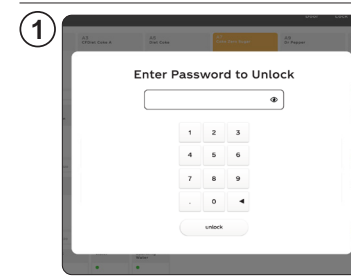

Access crew dashboard. Tap login, in the header, and type the manager passcode 2653.

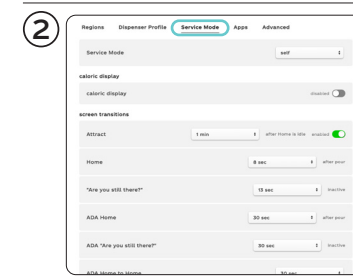

Select settings and then choose Service Mode in the secondary navigation.



Slide caloric display toggle to enabled to activate. Slide toggle icons to create a portion size. Green/right is enabled; Gray/left is disabled.

NOTE: The initial setting for the caloric display feature will be disabled.



TIP: Create custom names and sizes by tapping on the drink name or portion size to adjust. Then click exit to return to the consumer interface.

Using & pairing with myCoke mobile app

myCoke Mobile App

Enables crew members to monitor dispenser ingredients via their smart devices, with no disruption to dispenser function. It helps crews efficiently maintain the dispenser by notifying them of required cartridge change-outs & cleaning tasks.

My Equipment

Shows the status of all machines in a particular outlet.

Ingredient Status Gauges

Highlights important information such as sold-out product, prime needed, and time remaining.

Cleaning Check Lists

Syncs status of cleaning and maintenance tasks between crew members.

About

Provides specific and detailed information for each dispenser.

Training

Creates easy access for crew to platform-specific training materials and troubleshooting guides on Crew Connect.

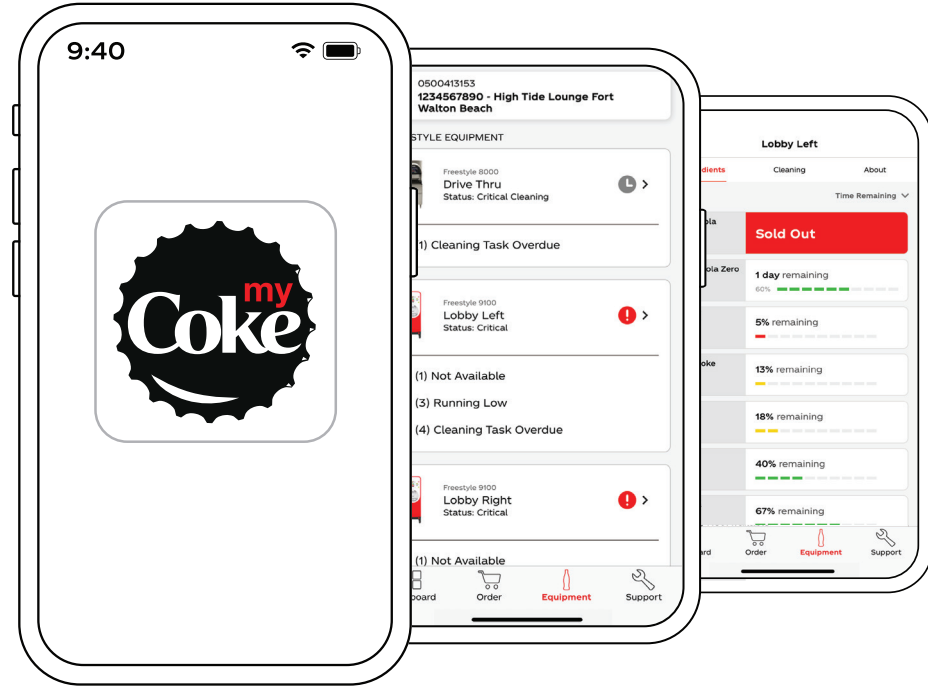

Using & pairing with myCoke mobile app

Pairing with app

- 1 **Download myCoke app**
Available in the App Store or Google Play.
- 2 **Add a dispenser**
Using the Equipment tab, click Add a Dispenser, or the + symbol to pair with your device.
- 3 **Enter a display name**
This name will be visible to other crew members.
- 4 **Scan QR code**
myCoke will walk through a series of instructions for the dispenser's dashboard to display the QR code. Scan the QR Code shown on the dispenser to complete the pairing process. The myCoke app will automatically pair with other dispensers in outlet.

NOTE: When prompted, be sure to allow camera access and notifications.

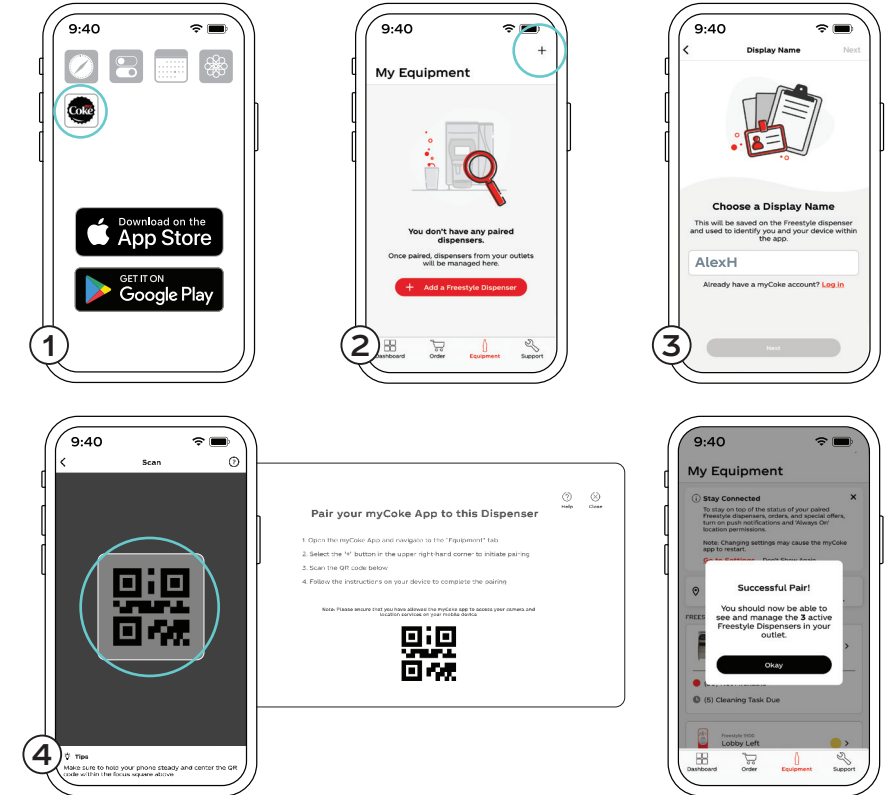

Replacing cartridges and NNS

Replacing product cartridges or NNS starts with knowing when a cartridge or NNS is empty or unavailable.

1 The screenshot shows that the Sprite ingredient is empty. As a result, the brand button is grayed out and will say "Not Available" when selected.



2 View the amount of ingredient remaining within each cartridge or NNS by accessing the dashboard.

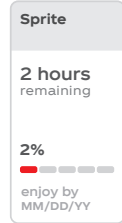

Reference the level indicator next to the brand.

NOTE: Time remaining is an estimate based on historical consumption data. This feature may take up to three weeks after install.

For best practices regarding cartridge maintenance, see page 28.

3 Remove the cartridge tray with empty product cartridge from the dispenser.

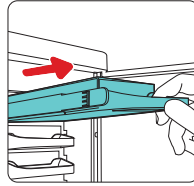

4 Separate the empty product cartridge from the plastic tray and recycle the outer paperboard box. Then clean tray with dish soap, followed by approved sanitizer solution (Kay-5 Sanitizer®).

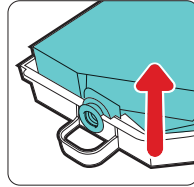

5 Dip a clean cloth in approved sanitizer solution, wipe the probes (that insert into cartridges), then dip a new clean cloth into the sanitizer solution and wipe the probes again to sanitize.

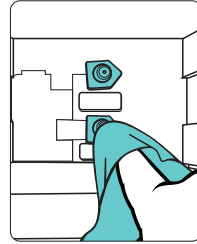

6 Open new cartridge using perforated cartridge opening flap.

CAUTION: DO NOT use a sharp object to open.

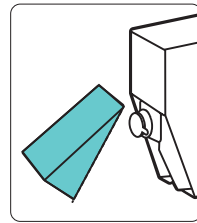

7 Remove (outer) white dust-cap prior to placing cartridge into plastic tray.

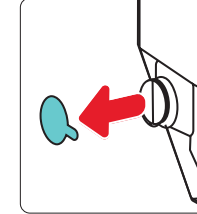

8 Place product cartridge into plastic tray and ensure plastic fitment from cartridge pouch aligns with tray.

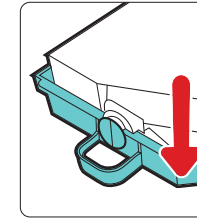

9 Ensure the product cartridge is aligned with the slot found on the plastic tray.

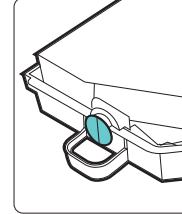

10 Remove foil safety seal prior to inserting into the dispenser.

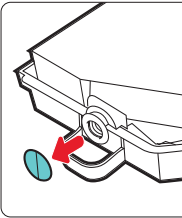

11 Insert the cartridge tray into the slot and push until you hear the latch click into place.

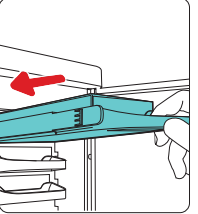

12 Close the door and follow on-screen instructions to complete the cartridge prime process. (See page 13).

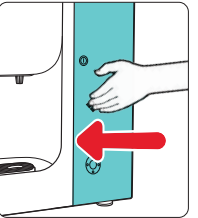

☆ NNS (Non-Nutritive Sweetener) is used for all low/no-calorie beverages. NNS arrives in a SmartPAK™ cartridge and is replaced just like other product cartridges. They will always be in the number one (1) or top slot in the cartridge shelf.

! Always replace any missing or damaged plastic trays immediately to prevent dispensing issues. Plastic trays can be ordered by calling your local service technician.

Replacing HFCS (high fructose corn syrup)

When to replace HFCS

Understand how to determine if the HFCS BIB (bag-in-box) needs to be replaced.

Pour screen

All sweetened beverage buttons will be grayed out.

Resetting HFCS

Once the new HFCS box is installed, press the **HFCS box** to reset, and the prime function will automatically follow.

Replacing HFCS and cleaning connector

- 1 Double check to see how much product is left by lifting the box.

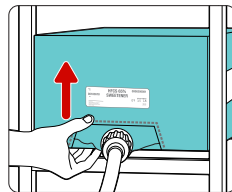

- 2 Use a cloth to catch any spills, and turn connector counter-clockwise to loosen.

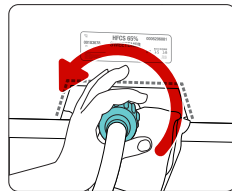

- 3 Remove connector and replace with new HFCS sweetener BIB. **NOTE:** Always check product is within the Enjoy By Date.

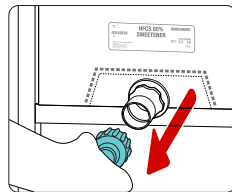

- 4 Scrub using the blunt end of the nozzle brush (#149326) and soak in approved sanitizer solution (Kay-5 Sanitizer®).

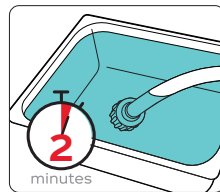

Wait two minutes and repeat with clean sanitizer then, air dry.

- 5 Open the box and pull out the fitment.

CAUTION: DO NOT use a sharp object to open.

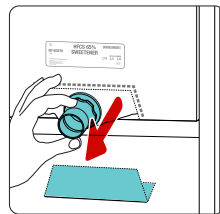

- 6 Attach the connector to the fitment and turn clockwise to tighten.

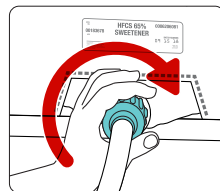

Helpful cleaning tips

Coca-Cola recommends **Kay-5® Sanitizer**, or a comparable food-grade chlorine sanitizer.

If using Kay-5 Sanitizer, add 1oz (28.4g) packet of Kay-5 Sanitizer to 2½-gallons (9.5L) of fresh, warm water in a clean bucket.



! When using a chlorinated detergent other than Kay-5 Sanitizer, follow the instructions to produce a **100 ppm chlorine sanitizer solution.**

☆ Kay-5 Sanitizer, cleaning brush and replacement nozzle can be ordered by calling your local service technician.

⊘ CAUTION: What NOT to do...

DO NOT use bleach or any unapproved chemicals!



DO NOT soak any parts overnight!



DO NOT use scouring pads, steel wool or any abrasive material. It will scratch the surface and result in rusting/pitting!

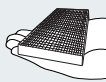

DO NOT use paper towels. They may break apart and clog the drain!

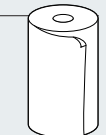

DO NOT pour hot liquids into the drain (greater than 125°F / 51.6°C)!

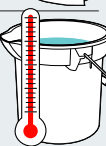

Cleaning nozzle, injector ring and ice chute

Cleaning nozzle and injector ring

- ① Using a clean cloth, twist the nozzle clockwise and pull down to remove.

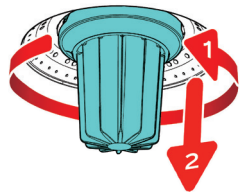

- ② Scrub nozzle with blunt end of nozzle brush and soap. Rinse with warm water. Allow to air dry.

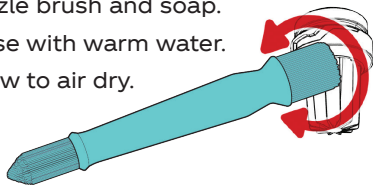

- ③ Submerge nozzle in sanitizer for two minutes. Agitate to remove air pockets.

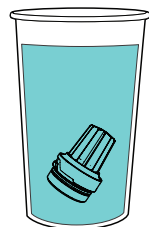

- ④ Scrub ring area including holes with pointed end of nozzle brush dipped in sanitizer.

Scrub inner injector ring with wire-handled brush dipped in sanitizer.

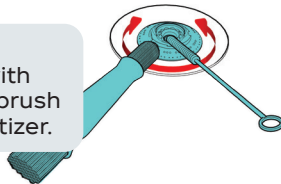

- ⑤ Wipe ring with clean cloth and sanitizer until it comes away clean. Wait two minutes. Repeat scrubbing and wiping ring with clean sanitizer.

- ⑥ Re-insert nozzle by pushing upward and rotating clockwise.

Pour remaining sanitizer down the dispenser drain.

Allow to air dry.

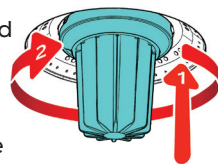

Cleaning ice chute

- ① Turn off power using the green power button.

- ② Using the ice chute brush and approved sanitizer solution, clean the inside of the chute.

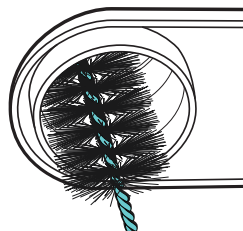

- ③ Wait two minutes to allow to air dry, then repeat step 2 with fresh sanitizer solution.

- ④ Wipe the outside of the ice chute tip using a clean cloth and fresh sanitizer solution. Allow to air dry before resuming normal operation.

Cleaning ice bin

- ① Remove all ice by using the on screen ice button (if a top-mounted ice maker is installed, follow manufacturer's recommendation for cleaning).

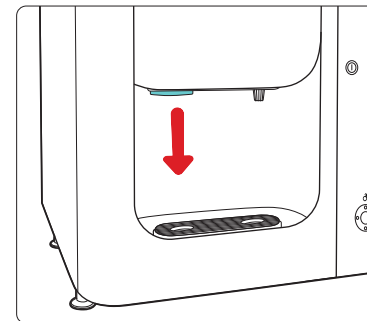

- ② Power off and unplug the dispenser. Remove the ice bin lid and pour warm water slowly into the bin to melt the remaining ice.

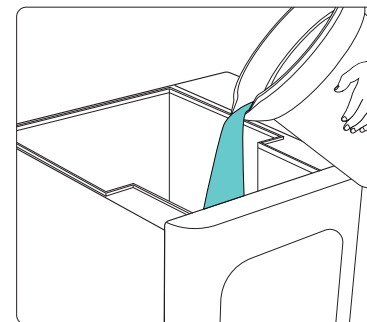

- ③ Spray approved sanitizer solution (Kay-5) onto all internal surfaces of ice bin and both sides of ice bin lid.

Wipe or scrub areas within reach inside the bin with either a clean cloth or optional ice bin brush (small parts #149322).

Wait 2 minutes and repeat with fresh sanitizer solution. Allow the ice bin to air dry before refilling with ice.

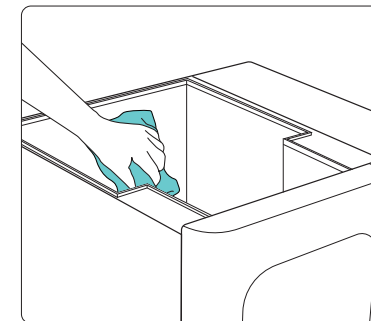

- ④ Refill the ice bin with fresh ice and replace lid. See page 9 on how to fill the ice bin.

NOTE: For complete disassembly instructions, contact your Coke representative.

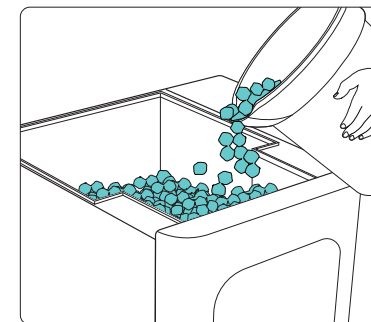

Cleaning drain and cup rest

- ① Power off using the green power switch.

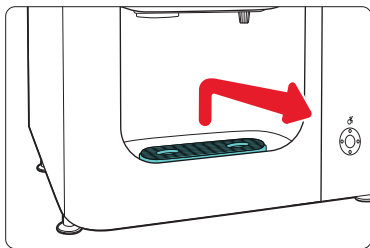

- ② Dip a clean cloth in approved sanitizer solution.

Clean the cup rest and drain strainer.

Wait 2 minutes and repeat with fresh sanitizer solution. Allow to air dry.

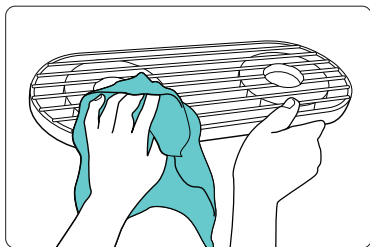

- ③ Use the drain cleaning brush (small part #144925) to scrub the dispenser drain.

Pour remaining sanitizer solution slowly down drain. Ensure the drain empties properly.

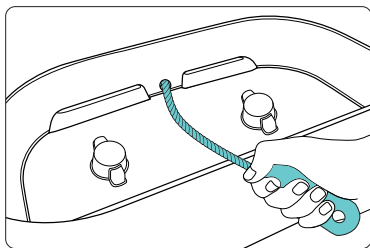

- ④ Replace the drain strainer and cup rest.

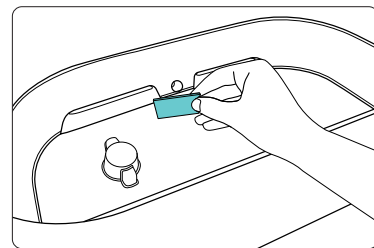

- ⚠ **TIP** If drip tray fails to drain, remove the drain strainer and clear the area of any trash.

Press the drain plunger into the mouth of the drain, then push the plunger rod firmly to force air down the pipe to clear the clog.

Resume cleaning with drain cleaning brush.

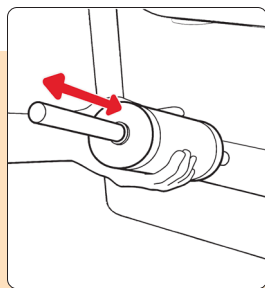

Cleaning exterior surfaces

- ① Using a clean cloth and approved sanitizer solution, wipe all exterior surfaces.



- ⚠ Frequently clean high touch point areas such as touch screen.

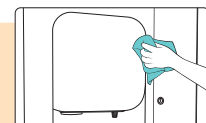

- ② Crew should frequently clean areas that accumulate drips such as backplash.

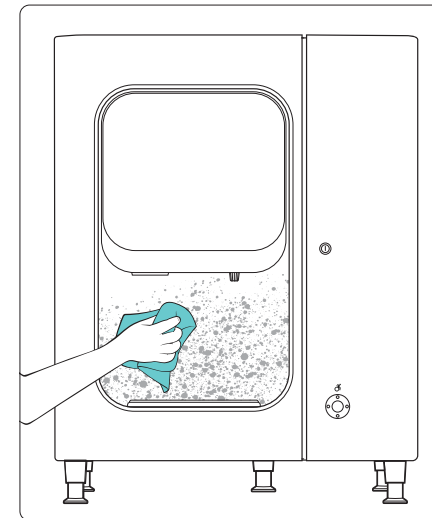

- ③ Wipe interior of cartridge door as needed.

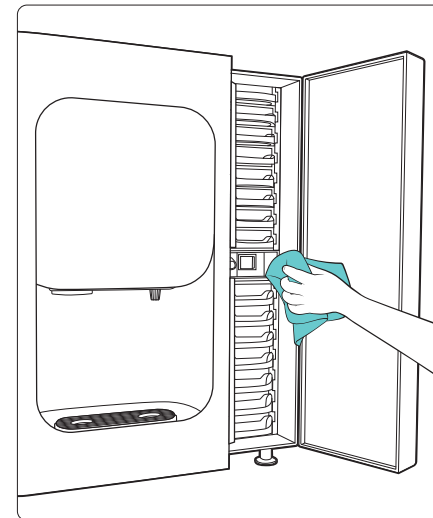

Cartridge maintenance

SmartPAK™ (paperboard) cartridges are lightweight, recyclable, and designed to optimize backroom storage space.

Inventory and quick replacements

- Be prepared during rush periods! Place fast-moving product cartridges in extra trays and stage near dispenser for fast change outs.
- Use your oldest product cartridges on hand first, i.e. **“First-in, First-out.”**
- Always ensure product cartridges are organized by “Enjoy By Date” to effectively manage inventory.

Cartridge trays

The Coca-Cola Freestyle Flex uses the black plastic, push-click cartridge trays. The trays are designed to hold a single product cartridge.

Storage conditions

Avoid storing cartridges and plastic trays near any heat source, standing water, or cleaning solutions.

Cleaning trays

Push-click cartridge trays should be ‘hand washed’ before insertion of a cartridge. **NEVER PLACE IN A DISHWASHER.** Placing trays in a dishwasher may warp the trays over time. Use dish soap, followed by Kay-5 Sanitizer® or approved equivalent and allow to air dry.



Shake cartridge before installation into dispenser for better results with product.

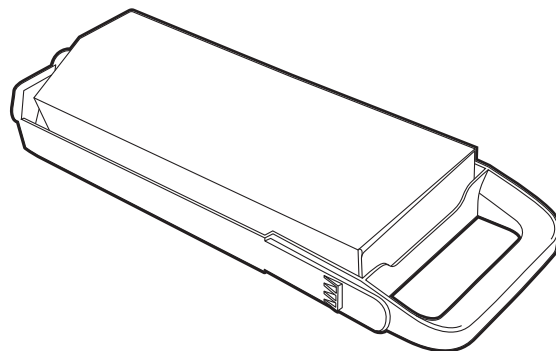
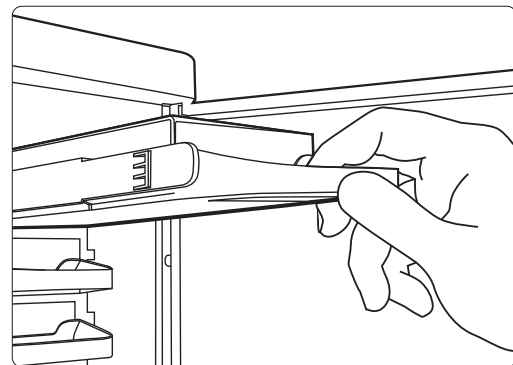

Small parts

To request a small parts order, contact your local service technician. More information can be found at crewconnect.coca-cola.com.



Nozzle Tip
#144700

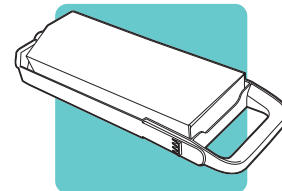

Cartridge Tray
#141103



Cartridge Door Key
#141343

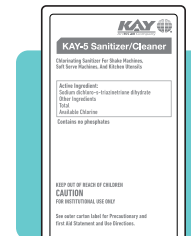

Kay-5 Sanitizer
#24041



Microfiber Cloth
#127723



Ice Chute Brush
#143257

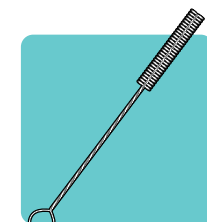

Wire Handled Nozzle Brush
#1145555

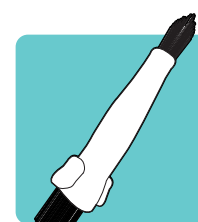

Nozzle & Injector Ring Brush
#149326

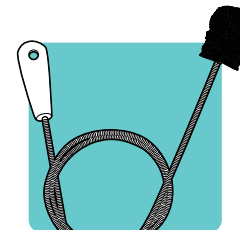

Drain Cleaning Brush
#144925

CREW CONNECT

We are committed to maximizing the operational and business performance of your Coca-Cola Freestyle® by providing your crew with the support they need.

Premium Support Solutions

TRAINING

Training resources to keep your crew in-the-know, from first installation, through new hires, to new upgrades in equipment or processes.

- » Live Crew Onboarding
- » Crew Connect
- » Crew Training Reference Guide
- » Troubleshooting Guides

TOOLS

Our materials and support infrastructure make maintenance and cleaning easier – and keep your dispensers running smoothly.

- » QR Video Decals
- » Crew Reminders & Checklists
- » On-Dispenser Instructions
- » myCoke app

SERVICE

We are constantly innovating to better serve your operational and business needs. For assistance on servicing and parts, contact your local service provider for details.

- » On-Site Service
- » Remote Software Diagnostics & Analytics



To find out what **Coca-Cola Freestyle Crew Connect** can do for your business, contact your Coca-Cola Sales Representative.



For crew training videos, visit crewconnect.coca-cola.com



THE *Coca-Cola* COMPANY